



10 DIGITAL OUTPUT MODULE WITH MODBUS PROTOCOL ON RS485

Z-10-D-OUT

GENERAL SPECIFICATIONS

- 10 MOSFET outputs with shared negative pole collectively fed with from 6 to 40V DC, current carrying capacity 0.5A, resistive load 0.5A inductive load with maximum switch-on/switch-off cycle frequency of 2 cycles/second.
- Removable terminals with section of 2.5 mm²
- Outputs protected against short-circuit.
- Setting of an output safety status upon starting or whenever communication is lacking.
- Safety time can be set from 10 ms to 2000 s.
- Diagnostics for cut-off loads and short-circuits.
- Measurement of the load power supply voltage.
- Possibility of ON-LINE configuration.
- RS485 serial communication with MODBUS-RTU protocol, maximum 32 nodes.
- 1500V AC output insulation compared to communication bus.
- Power supply and serial connection wiring facilitated by means of a bus that can be housed in the DIN guide.
- Insertion and extraction of bus without interruption of communication or system power supply.
- Communication times below 10 ms (@ 38400 baud).
- Connection distance up to 1200 m.

TECHNICAL SPECIFICATIONS

Power Supply:	10–40 Vdc, 19–28 Vac 50-60Hz, max 2.5W
Communication port:	Two-wire RS485 with settable speed (9600 , 19200 , 38400 , 57600 Baud rate) and type of parity (None, Even, Odd)
Protocol:	Modicon MODBUS RTU
Outputs:	10 MOSFET outputs with shared negative pole collectively fed with from 6 to 40V DC, current carrying capacity 0.5A resistive or inductive load
Ambient conditions:	Temperature: 0..55°C , Min.: 30% Max. 90% humidity at 40°C non-condensing, Installation class II, pollution rating 2
Protection rating:	IP20
Weight, dimensions:	150g , 100 x 17,5 x 112 mm
Standards	 <p>The instrument complies with the following standards: EN50081-2 (electromagnetic emission, industrial environment) EN50082-2 (electromagnetic immunity, industrial environment) EN61010-1 (safety) All circuits must be insulated with double insulation against circuits under dangerous voltage. The power supply transformer must comply with EN60742 standards for insulation transformers and safety transformers.</p>



INSTALLATION

The module has been designed for vertical installation on a DIN 46277 guide.
For optimal operation and long life, adequate ventilation must be provided for the module(s), avoiding positioning channels that obstruct the ventilation louvers.
Avoid fitting modules above equipment that generates heat; you are advised to fit them at the bottom of the panel.

HARSH OPERATING CONDITIONS:

When the modules are fitted side by side it may be **necessary to separate them by at least 5 mm** if the panel temperature is above 45°C and operating conditions are harsh.

The following constitute harsh operating conditions:

- High power supply voltage (> 30Vdc / > 26 Vac).
- *Elevated output current*
- *Frequent commutation of loads that are highly inductive or incandescent lamps*
- *Horizontal assembly*

NOTE: Assembly performed using the appropriate DIN guide connectors ensures the easy assembly and correct ventilation of the modules; see our articles

Z-PC-DIN2: 2-position bus

Z-PC-DIN4: 4-position bus

Z-PC-DIN8: 8-position bus

Z-PC-DINAL: termination with terminal boards for RS485 serial communication and power supply.

ELECTRICAL CONNECTIONS

Power supply and RS485 serial communication port:

The electrical connections for the power supply and RS485 bus are usually made available by using the bus for the Seneca DIN guide. The connector connections are shown in the figure below:

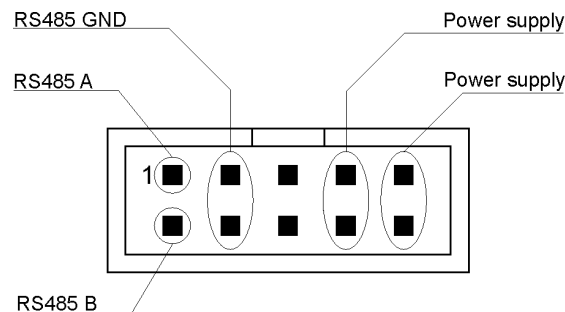

Note: The power supply voltage must be between 10 and 40 Vdc (any polarity) or 19 and 28 Vac; see also section ***INSTALLATION***.

The upper limits must not be exceeded as this can seriously damage the module.

The power supply source must be protected against module malfunction by a 0.5A quick-break fuse.

General:

Output status can be set in the Modbus 40003 register. The bits from 0 to 9 in this register indicate respectively the statuses of outputs 1 to 10.

Resistive, inductive or capacitive loads can be connected to the output terminals.

Warning:

- The power supply for these loads **MUST** be provided directly from terminal 1 (+6V DC \leq Val \leq +40V DC). The return currents of the loads **MUST** be connected together and to terminal 12.
- The total current, the sum of the maximum peak currents of all the loads that can enter from terminal 1 **MUST be limited to 8A** with quick-break fuse or equivalent protection.
- In order to obtain recognition of the output short-circuit, the power supply to the loads must withstand the short-circuit current in the range of 5A to 7A without permitting the voltage to fall below 6V.
- The module keeps the overheating or short-circuit of the outputs under constant control. Whenever an output signals overheating or short-circuit, a time begins running that is set using a configuration parameter (40016.8:40016.15). If the short-circuit or overheating disappears before this time elapses, the temporary overheating or short-circuit is ignored. If, on the other hand, the temporary overheating or short-circuit remains after this time, the output is disabled and the corresponding bit in Register 40004 is set to zero.
- During this period, the protection against overheating by the output transistors connects and disconnects the load in order to keep the temperature within acceptable limits. Overheated or short-circuited outputs are signalled in the respective registers (40007 and 40008).
- **After an output has been subjected to short-circuit or overheating, the corresponding bit in Register 40004 must be set to zero before it can be re-enabled.**

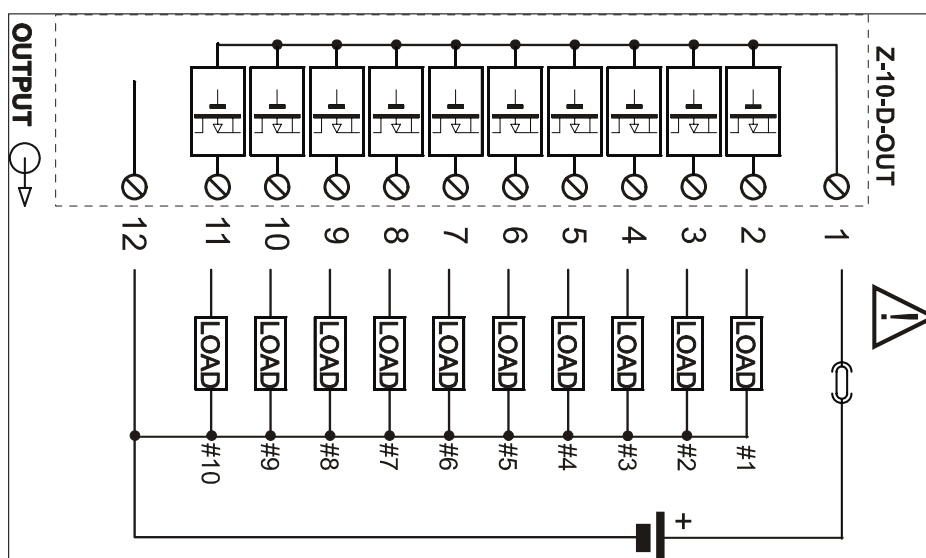
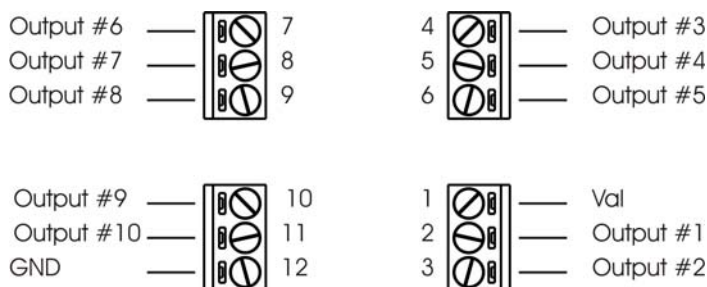

Z-PC Line

Z-10-D-OUT

Modbus module with 10 MOSFET digital outputs

Installation Manual

- Contents:**
- General specifications
 - Technical specifications
 - Modbus connections rules
 - Installation rules
 - Electrical connections
 - DIP-switches settings
 - Modbus basic register and LEDs signalling
 - Factory settings and advanced settings.



SENECA s.r.l.
Via Germania, 34 - 35127 - Z.I. CAMIN - PADOVA - ITALY
Tel. +39.049.8705355 - 8705359 - Fax +39.049.8706287
For manuals, and configuration software, see www.seneca.it

This document is property of SENECA srl. Duplication and reproduction are forbidden, if not authorized. Contents of the present documentation refers to products and technologies described in it. All technical data contained in the document may be modified without prior notice. Content of this documentation is subject to periodical revision.

GENERAL SPECIFICATIONS

- 10 MOSFET outputs with shared negative pole, the outputs can be collectively connected an external supply with maximum 30 Vdc and minimum 6 Vdc.
- Digital output carrying capacity: 0.5 A inductive load and 0.5 A resistive load with maximum switch-on / switch-off cycle frequency of 2 cycles/second.
- Removable terminals with section of 2.5 mm².
- Outputs protected against short-circuit.
- Outputs safety status setting at power on and in case of lacking communication.
- Safety time can be set from 33 ms to 2184 s.
- Diagnostic for short-circuits.
- Measurement of the load power supply voltage.
- Possibility of ON-LINE configuration.
- RS485 serial communication with Modbus-Rtu protocol, maximum 64 nodes.
- 1500 Vac output isolation compared with other low voltage circuits.
- Easy connections for power supply and serial communication from seneca bus for standards DIN 46277 rail.
- Module insertion or extraction from seneca bus without interruptions for communication and power supply.
- Communication time below 10 ms (@ 38400 Baud).
- Connection distance up to 1200 m.
- Set the Modbus address and the Baud rate with DIP-Switch.

TECHNICAL SPECIFICATIONS

Outputs	
Type output	MOSFET with shared negative pole.
Digital output carrying capacity	0.5 A resistive load
External power supply	30 Vdc
Number of channel	10
Maximum rated current of Mosfet	0.5 A
Maximum rated voltage of Mosfet	30 VDC
Maximum output clamp energy capability	40 mJ with inductive load
Time delay mosfet	5/2 ms

Power supply	
Voltage	10 ..40 V _{oc} 19 ..28 V _{ac} @ 50 ..60 Hz
Consumption	Typical: 1.5 W, Maximum: 2.5 W

Environmental condition	
Temperature	-10 ..+65°C, (-10 ..55°C UL)
Humidity	30 ..90% a 40°C not condensing
Altitude	Up to 2000 m a.s.l.
Storage Temperature	-20 ..+85°C
Degree protection	IP20

Connections	
Connections	Removable 3-way screw terminals, 5,08 pitch Rear IDC10 connector for DIN 46277 rail

Box / Dimensions	
Dimensions	L: 100 mm; H: 112 mm; W: 17,5 mm
Box	PBT, Black

Isolations 1500 V	

Standards	
	EN61000-6-4/2002-10 (electromagnetic emission, industrial environment).
	EN61000-6-2/2006-10 (electromagnetic immunity, industrial environment)
	EN61010-1/2001 (safety). All circuits must be isolated from the other circuits under dangerous voltage with double isolation. The power supply transformer must comply with EN60742: "isolated transformers and safety transformers".

ADDITIONAL NOTES:
Use in Pollution Degree 2 Environment.
Power Supply must be Class 2.
When supplied by an Isolated Limited Voltage/Limited Current power supply a fuse rated max 2.5A shall be installed in the field.

MODBUS CONNECTIONS RULES

- 1) Connect the module into the DIN rail (max 120)
- 2) Use a suitable length cable to connect the remote modules. In the table below the relative data to the length of the bus and length of the cable are reported.
-Bus length: Maximum length of the Modbus network. The bus length is determined from the length of network that has the two modules who has been switched on the bus terminator. (see scheme 1).
-Drop length: Maximum length of branch (see scheme 1).

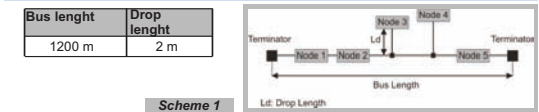

For the maximum performances it's recommended to use a specific shielded cable, as an example BELDEN 9841.

INSTALLATION RULES

The module is designed to be installed, in vertical position, on DIN 46277 rail. For the best performance and long life cycle the cables raseways and other objects in the control panel must be placed not to obstruct the slots of the module that must be ventilated. Never install the modules near heat sources. It's advised the installation of the module in the lower part of the control panel.

Inserting in the DIN rail

As it is illustrated in the next figure:

- 1) Insert the module IDC10 rear connector on the DIN rail free slot (the inserting is unequivocal because the connectors are polarized).
- 2) The module can be fixed on the DIN rail through the clench of the two hooks in the lower part of it.

ELECTRICAL CONNECTIONS

Power supply and Modbus interface

From IDC10 (rear connector of the module) or Z-PC-DINAL2-17,5 (optional) are available power supply and Modbus interface. In the next page are shown the use specifications of IDC10 and Z-PC-DINAL2-17,5.

Rear connector (IDC10)

In the figure the meaning of the IDC10 connector pins is showed. This connector can be used in alternative to the screw terminals blocks

Utilizzo Accessorio Z-PC-DINAL2-17,5

If Z-PC-DINAL2-17,5 accessory is used, the power supply signals and communication signals may be provided by the terminals block into the DIN rail support. In the figure are shown the meaning and the position of the terminal blocks. The DIP-switch set the 120 Q terminator is used only for CAN communication. GNDSHLD: Shield to protect the connection cables (recommended).

Digital Outputs

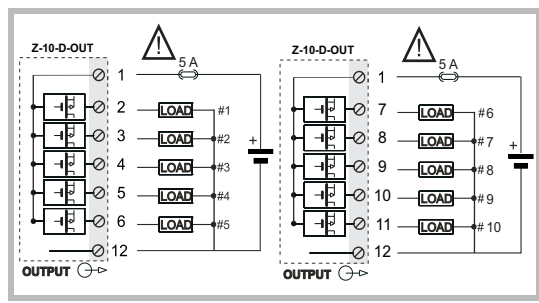

Warnings:

- The power supply for these loads **MUST** be provided directly from terminal 1 (maximum 30 Vdc). The return currents of the loads **MUST** be connected together and to the terminal 12.
- The total current, the sum of the maximum peak currents of all the loads that can enter from terminal 1 **MUST BE LIMITED TO 5 A** with quick-break fuse or equivalent protection.
- In order to obtain recognition of the output short-circuit, the power supply to the loads must withstand the short-circuit current, without permitting the voltage to fall below 6 V.
- The digital outputs can be activated only for an external voltage supply higher than 6 V in the screw terminals 1 and 12.

DIP-SWITCHES SETTING

The DIP-switches positions defines the Modbus communication parameter: Address and Baud rate. In the following table the Baud rate and address value are listed as a function of the DIP-switches position:

DIP-switches table			
POSITION	BAUD RATE	POSITION	ADDRESS
00xxxxxxx	9600	xx00001xx	# 1
01xxxxxxx	19200	xx00010xx	# 2
10xxxxxxx	38400
11xxxxxxx	57600	xx11111xx	# 63

POSIZIONE	BAUD RATE	POSIZIONE	ADDRESS
xx000000	From EEprom	xx000000	From EEprom

Nota: when DIP-switches from 3 to 8 are in OFF, communication settings are retrieved from EEprom
Nota 2: The termination of RS485 communication must be enabled only to the ends of the communication line.

MODBUS BASIC REGISTER AND LED SIGNALLINGS

Holding register		
Register	Name	Description
40003	OUTPUT	Set the bit in the register to control the relative output: Output 1: 40003.0 Output 2: 40003.1 Output 3: 40003.2 Output 4: 40003.3 Output 5: 40003.4 Output 6: 40003.5 Output 7: 40003.6 Output 8: 40003.7 Output 9: 40003.8 Output 10: 40003.9

Coil registers

Registers	Name	Description
10001	OUTPUT1	as bit 0 of register 40003
10002	OUTPUT2	as bit 1 of register 40003
10003	OUTPUT3	as bit 2 of register 40003
10004	OUTPUT4	as bit 3 of register 40003
10005	OUTPUT5	as bit 4 of register 40003
10006	OUTPUT6	as bit 5 of register 40003
10007	OUTPUT7	as bit 6 of register 40003
10008	OUTPUT8	as bit 7 of register 40003
10009	OUTPUT9	as bit 8 of register 40003
10010	OUTPUT10	as bit 9 of register 40003

LEDs signalling

LED	STATE	Meaning of LEDs
PWR	On	Power supply presence.
FAIL	Blinking	*See advanced settings.
RX	Blinking	Received data.
	On	Error connection.
TX	Blinking	Received data.

FACTORY SETTING AND ADVANCED SETTING

Factory settings

- Tutti i DIP-switch in OFF.**
- Modbus protocol: - Communication parameters : 38400 8,N,1 Addr. 1
 - Digital Outputs : NORMAL OPEN
 - Safety state : ENABLE
 - Safety timer : DISABLE
 - Reversal of status relay : DISABLE
 - Dealy short-circuit recognition: up to 1s
 - Control supply voltage output: ENABLE

Advanced settings

- Constant control of the outputs short-circuit with a settable diagnostic modbus register .
- Control the outputs short-circuit with a settable timer in the modbus register.
- Control and set the blinking of fail LED with a settable modbus register .
- Set a timer to regulate the time after that the output will be set in the short-circuite state.
- Set a safety timer to regulate the time that the outputs will be set in the safety state.
- Set the outputs safety state that will be enabled in case of lost communication for a time equal to settled safety timer.

Variations of standard parameters are possible by using configuration softwares Z-NET and EASY-Z-PC (www.seneca.it). For more information about a list of all register and their function consult the USER manual

